

## A RAND NOTE

COMBAT OPERATIONS DECISIONMAKING IN TACTICAL  
AIR COMMAND AND CONTROL

R. Stockton Gaines, Willard E. Naslund and  
Ralph Strauch

December 1980

N-1633-AF

Prepared For

The United States Air Force



The research reported here was sponsored by the Directorate of Operational Requirements, Deputy Chief of Staff/Research, Development, and Acquisition, Hq USAF, under Contract F49620-77-C-0023. The United States Government is authorized to reproduce and distribute reprints for governmental purposes notwithstanding any copyright notation hereon.

The Rand Publications Series: The Report is the principal publication documenting and transmitting Rand's major research findings and final research results. The Rand Note reports other outputs of sponsored research for general distribution. Publications of The Rand Corporation do not necessarily reflect the opinions or policies of the sponsors of Rand research.

## A RAND NOTE

COMBAT OPERATIONS DECISIONMAKING IN TACTICAL  
AIR COMMAND AND CONTROL

R. Stockton Gaines, Willard E. Naslund and  
Ralph Strauch

December 1980

N-1633-AF

Prepared For

The United States Air Force





PREFACE

This Note, part of Rand's work in tactical air command and control, attempts to detail some of the organizational and human processes that actually occur in a command center, and to identify ways in which technology might be used to enhance performance. The vehicle used in presenting these ideas is the Combat Operations portion of a Tactical Air Control Center, but much of the analysis of individual and organizational procedures and functions is relevant to other command and control situations as well. The views presented here, being based in part on observations of particular command and control situations, are rather different from what one finds in the official literature (organization manuals, regulations). The findings are intended to demonstrate what actually happens, and may thereby contribute to the design of better command and control systems.

The Note should be of interest to those concerned with command and control, organizational decisionmaking, and crisis management. While it does address some technological issues, it is primarily concerned with the "people" side of command and control, an aspect of command and control that has received far too little attention to date.

This work was done under the Project AIR FORCE research project "Tactical Air Command and Control."



SUMMARY

Command and control is today receiving a great deal of attention, but most of it is focused on technological problems. In contrast, command and control per se has been neglected. Little has been written about the actual operations of command and control, and analyses of the pros and cons of different organizations, procedures, and methods of obtaining command and control objectives cannot be found. This report--an initial step in the area of tactical air force employment in a theater conflict--attempts to show that there are other factors of command and control worth considering besides issues related to technology.

The nervous system of a combat military organization is its command and control system. At an abstract level, it can be thought of as encompassing two primary activities: perceiving and deciding. The situation must be perceived and understood, and the threats and opportunities it provides assessed. Actions must then be taken, within the capabilities available, to meet those threats and exploit those opportunities. As the situation changes, those changes feed back into the perceiving and deciding, in a continuous process.

In practice, this conceptually simple process takes place within a large and complex organizational structure in which responsibility and authority are divided among different levels of command and different functional organizations at each level. The processes of perceiving and deciding are correspondingly fragmented, with no element having more than a fraction of the information available to the total organization

and with many elements contributing to the process by which decisions are made for the organization as a whole.

This report describes this process in the Tactical Air Control System (TACS), the command and control structure for tactical air forces. We then focus in more depth on a particular portion of that process, the "Combat Operations" activity concerned with monitoring combat operations as they occur and modifying them if necessary to adjust to changing circumstances.

The Combat Operations portion of a Tactical Air Control Center (TACC) can be thought of as a decisionmaking entity in which incoming information about the state of an ongoing conflict is used to manage the employment of airpower resources in that conflict. Combat Operations is a group decisionmaking process, in which many people make and contribute to decisions, and there is no single decisionmaker. We examine the nature of that process, and discuss the roles of the various participants.

Automation of the TACS is a significant issue facing command and control planners, and will continue to be so in the future. A major question is how much to try to automate and how to go about it. We argue in favor of gradual evolutionary development rather than attempts at revolutionary change in a single step. As the TACC is automated, significant changes will occur in important areas of Combat Operations decisionmaking, and some of those changes could be detrimental if made too hastily and without sufficient thought to their operational consequences. Some such areas are discussed, including manpower requirements, information management, and the replacement of voice with digital communications.



Of particular concern, perhaps, is the issue of coherence between Combat Operations decisionmaking and that which goes on in the rest of the TACS. While it is not possible to predict the behavior of a wartime TACC with certainty on the basis of peacetime exercises and other peacetime evidence, it does appear that many of the decisions made in Combat Operations are made on the basis of very local considerations, with insufficient attention to where they fit in the broader scheme of things. This is due partly to the difficulties in obtaining and accessing relevant information in the current manual system, and partly to other causes. Whatever its causes, it does represent a major shortcoming of the current system, with potentially serious consequences in combat.



CONTENTS

PREFACE ..... iii  
SUMMARY ..... v  
FIGURES ..... xi

Section

I. INTRODUCTION ..... 1  
II. THE TACTICAL AIR CONTROL SYSTEM ..... 4  
    COMMAND AND CONTROL AS PERCEIVING AND DECIDING ..... 12  
III. COMBAT OPERATIONS DECISIONMAKING ..... 19  
    WHAT DO THEY DO NOW? ..... 20  
    COMBAT OPERATIONS AS A DECISIONMAKING ENTITY ..... 24  
    COMBAT OPERATIONS' DECISIONMAKING AS PART OF A LARGER  
    PROCESS ..... 32  
IV. AUTOMATION OF COMBAT OPERATIONS DECISIONMAKING ..... 39  
    ORGANIZATIONAL IMPACTS ..... 41  
    INFORMATION MANAGEMENT ..... 42  
    COMMUNICATIONS ..... 44  
    MANPOWER REQUIREMENTS ..... 46  
    EVOLUTIONARY DEVELOPMENT ..... 49



FIGURES

1. General Structure of the Tactical Air Control System .....	5
2. Tactical Air Control Function in the TACC .....	8
3. Combat Operations Organization .....	10
4. TACC Current Operations Arrangement for GALLANT EAGLE '78 .....	13
5. A Simple Abstract Model of C <sup>2</sup> Planning and Decisionmaking .....	16
6. An Abstract View of Combat Operations Decisionmaking .....	26



## I. INTRODUCTION

Tactical air power is an important component of modern military force. It provides an ability to deliver firepower across large geographical distances in relatively short periods of time. This firepower is potentially highly flexible. It can be directed and redirected, concentrated or dispersed as the occasion requires.

But like any other kind of military force, tactical air power must be effectively controlled and directed to achieve the ends for which it is employed. Choices must be made about these ends, and these choices must be translated into specific decisions about how the forces are to be employed to achieve them. Potential targets must be identified and evaluated, and those against which strikes are to be made must be selected. These decisions must then be transmitted to the forces involved in an efficient and timely manner. Post-strike results must be assessed, and the process continued. And through it all, coordination must be maintained within the tactical air forces themselves, as well with other military units. Command and control is the process through which this is done.

Command and control involves a combination of people and technology, principally communications and data processing technology. In recent years, the majority of the attention given command and control by the research community has been on the technological side. In this Note, we explore some of the "people" issues, and the relationships between the human organizations which comprise the command and control system and the technological systems which support them. The human and

organizational processes involved in controlling and directing tactical air forces are not well understood, and it appears difficult to see how new technological advances, such as computers, can be effectively utilized without such understanding. We attempt here to present a perspective on these processes, and to relate them to technological capabilities which might improve them. The reader should clearly understand, however, that this is not a paper about technology, but about command and control itself.

We will focus particularly on that portion of the command and control process occurring in the Combat Operations section of a Tactical Air Control Center (TACC). This includes the activities of monitoring and managing planned air operations as they occur, and of modifying those operations as necessary to adjust to changing circumstances. To place that examination in context, we will first briefly survey the larger command and control process within which it is embedded. We will then look in some detail at Combat Operations decisionmaking, and at some of issues raised by the introduction of automation into that process.

The next section of this Note sketches out the structure of the Tactical Air Control System (TACS), first broadly and then focusing more closely on that portion of the system of particular concern here, the Combat Operations section of the TACC. Following that we take a very general look at command and control as the nervous system of a military organization, analogous to the nervous system of a living organism. In Sec. III we discuss Combat Operations decisionmaking, focusing that discussion around a simple conceptual model we have found useful.



Section IV is devoted to a discussion of some specific issues raised by the automation of Combat Operations functions and the impact that automation would have on the activities of Combat Operations.

The main points we hope to make can be summarized as follows:

1. Command and control systems appear complex and difficult to comprehend when examined at a very detailed level. When they are viewed from a broader perspective, however, they can be seen in terms of relatively clear and understandable functions and processes.
2. Command and control involves the handling of large amounts of information, so that good communications and computer support are essential. The basic technological capabilities required to provide this support are relatively simple, and well within the state of the art.
3. Understanding the "people" part of the system, and accelerating the evolution of new concepts, organizations, and procedures, represents the real problem in improving command and control. This must be done in the context of the technological support that is possible, but should not be driven by that technology to the extent that has been true in the recent past.

## II. THE TACTICAL AIR CONTROL SYSTEM

Before examining the decision processes involved in the real-time management of tactical air forces, this section discusses the structure of the Tactical Air Control System in which this activity is embedded. The discussion will center on the deployable U.S. TACS, and will mention some of the more important variations that occur in the NATO context.

U.S.-only theater operations are conducted under the command of a Joint Task Force (JTF) commander. This commander is assisted by a senior Air Force officer who acts as the Tactical Air Force Commander (COMTAF). He directs the application of tactical air power through the Air Force's Tactical Air Control System (TACS). This system is generally referred to as the "deployable TACS," because it is intended to support U.S. forces wherever they might be deployed. It is the result of 40 years of evolution in tactical command and control.<sup>1</sup>

The major elements of the TACS are depicted in Fig. 1. The central node in this system, the Tactical Air Control Center (TACC), is of particular interest in this report. However, to understand its role it is necessary to have some appreciation of the rest of the system. Most of our discussion will be in terms of the USAF deployable TACS. Nevertheless, the ideas developed are, for the most part, intended to be general rather than specific to some particular existing command and control system.<sup>2</sup>

---

<sup>1</sup>See "Evolution of Command And Control Doctrine for Close Air Support," by Riley Sunderland, Office of Air Force History, Headquarters, USAF, March, 1973, for a partial description of this evolution.

<sup>2</sup>In the NATO Air Command and Control System (ACCS), for example, the functions performed by the deployable TACC are split between two

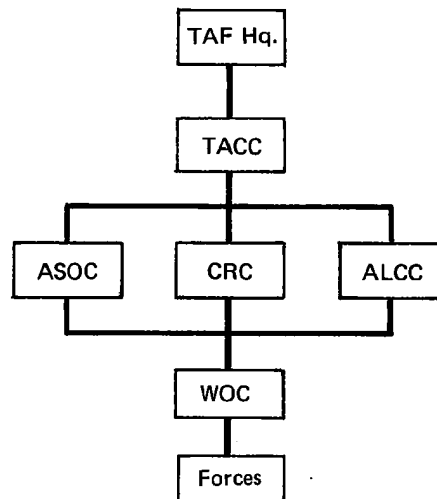

Fig. 1 -- General Structure of the Tactical Air Control System

Briefly, the functions of the various TACS elements depicted in Fig. 1 are as follows. The Tactical Air Force Headquarters consists of the COMTAF and his staff, and is responsible for the overall direction of the air war, and for planning that extends beyond a day ahead. The Tactical Air Control Center (TACC) is the TACS element having primary responsibility for day to day planning and control of tactical air operations. Some control functions are further delegated to subordinate elements--the Air Support Operations Center (ASOC) for close air support facilities, the Allied Tactical Air Force (ATAF) and the Allied Tactical Operations Center (ATOC). Much of what we say applies there as well even though the terminology is different. We will occasionally mention a NATO facility or concept where it is particularly important or where it will help the reader keep in mind the general nature of the discussion.

operations, the Control and Reporting Center (CRC) for defensive air operations, and the Airlift Control Center (ALCC) for airlift operations. Each of these has further subordinates, not shown here. In addition to its air defense responsibilities, the CRC has airspace management responsibilities for missions of all types. The Wing Operations Center (WOC), located at the Air Base level, is responsible for the detailed planning, the assignment of aircraft, and the briefing of aircrews required to launch individual air missions.

The basic choices which the use of military force requires, the choices of ends and objectives, are functions of command. They will be made at different command levels, ranging from the Tactical Air Force Commander in direct command of the tactical air forces, through the Joint Task Force Commander under whose overall direction the tactical air forces are operating, up to and including the National Command Authority. In practice, these choices will be shared, with higher echelons contributing direction and guidance which the lower echelons will flesh out, interpret, and implement.

Below the COMTAF, the function of control--of translating the command guidance and direction from above into the application of forces and of monitoring and directing that force application--resides in the TACS. The TACS has a partially centralized and partially decentralized nature. The TACC, under the authority of the COMTAF, is the central node of this large and complex system, the junction at which the lines of authority from the COMTAF and his superiors connect downwards with the remaining TACS elements. The TACC maintains overall authority and direction of the system, but, as mentioned above, delegates most

activity relating to the support of ground forces and to air defense and airspace control to other subordinate facilities.

We now move down another layer into the system, and look at the workings of the TACC itself. Internally, the TACC is divided along two dimensions, as shown in Fig. 2. The first division, shown vertically in the figure, is the split between Combat Plans and Combat Operations. The Combat Plans functions are those related to planning for future air operations, principally through the vehicle of the Air Tasking Order (ATO), or "frag" (an abbreviation for "fragmentary operations order," as it was once named). The ATO is prepared each day to cover the next day's operations. The Combat Operations functions include monitoring the implementation of the ATO and assigning forces to cover new targets which arise during the course of the battle. One common colloquial description of this division is to say that Combat Plans deals with "tomorrow's war," while Combat Operations is more concerned with "today's war."

The second important division, shown vertically in Fig. 2, is the division between Operations and Intelligence. Operations personnel (sometimes called "operators") are concerned primarily with friendly forces; they perform functions such as keeping track of available resources and assigning missions to particular tactical units. Intelligence personnel, on the other hand, are concerned primarily with the enemy and what he is doing; they perform functions such as situation assessment, maintaining enemy orders of battle (listings of enemy forces

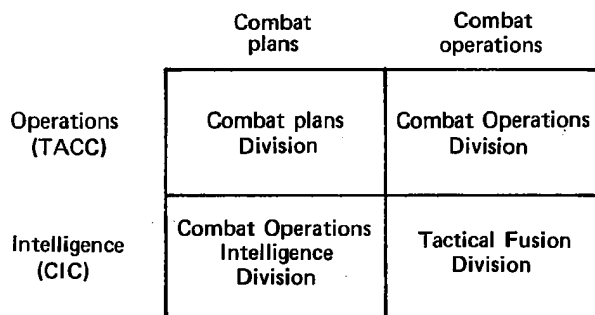

Fig. 2 – Tactical Air Control Function in the TACC

and capabilities), and identifying and recommending important targets.<sup>3</sup>

This basic structure has existed for many years, though the details have changed over time. The terms "Combat Plans" and "Combat Operations" are relatively new, having replaced the terms "Current Plans" and "Current Operations" within the past year. Until 1977, the term "Tactical Air Control Center" applied only to what is now the operations portion of the TACC, shown as the upper half of Fig. 2. The intelligence portion, the lower half of Fig. 2, was a separate facility known as the "Combat Intelligence Center" (CIC). In 1977, in order to

<sup>3</sup>Notice that the term "operations" appears in both of these dichotomies--in contradistinction to "plans" in the first and to "intelligence" in the second. Thus the operations personnel in Combat Plans may be called "operators" to distinguish them from the intelligence personnel, but called "planners" to distinguish them from the "operators" in Combat Operations. The terms "combat plans" and "combat operations" are sometimes used to refer to their respective halves of the total TACC (operations and intelligence together) and sometimes used to refer to the operations portion only.

promote greater interaction between operations and intelligence, the Tactical Air Command merged these two facilities into a single facility, still called the TACC. Familiar usage persists, however, and the TACC/CIC distinction can be found in some current documents.

To summarize to this point, the TACC is divided between operations and intelligence people and activities on the the one hand, and between today's and tomorrow's war on the other. On the Combat Plans side (that portion of the TACC that does the planning for "tomorrow's war"), the planners prepare a plan (the ATO) for the next day's activities based upon the guidance received from the COMTAF. The Combat Operations side of the TACC is responsible for conducting "today's" war. The operators manage execution of the ATO that Combat Plans prepared yesterday, modifying it as required by the realities of today's developing and perhaps unforeseen situation. The fusion personnel provide the near-real-time intelligence on targets and on threats, and nominate targets to the operators for immediate strikes.

Finally, let us move one more layer deeper and look at the internal organization of Combat Operations itself, as shown in Fig. 3. The man in overall charge is the Director of Combat Operations (DCO), the senior operations officer in the TACC. (He is also in overall charge of Combat Plans, but that aspect of his function does not concern us here.) The Combat Operations Division is headed by the Chief of Combat Operations Division (CCOD). He is assisted by the Senior Operations Duty Officer (SODO), who is responsible for managing the planned air operations (the ATO) and adjusting them as required by the changing situation, assigning or redirecting aircraft as necessary to new targets developed by the

Fusion Division. Under them are the various duty officers who manage specific types of air operations. These include the Fighter Duty Officers (FDOs), Recce Duty Officers (RDOs) and others concerned with special operations, search and rescue, etc. The Division also includes a number of technicians, plotters, and other supporting personnel.

On the intelligence side, the Tactical Fusion Division is headed by the Chief of Fusion Division (CFD). Under him are one or more situation analysts, a targets analyst, and supporting plotters and clerical personnel. There may be one current situation analyst responsible for the entire current situation, or the position may be split between a current situation analyst for air (CSA) and a current situation analyst for ground (CSG). The current situation analyst tracks the ongoing

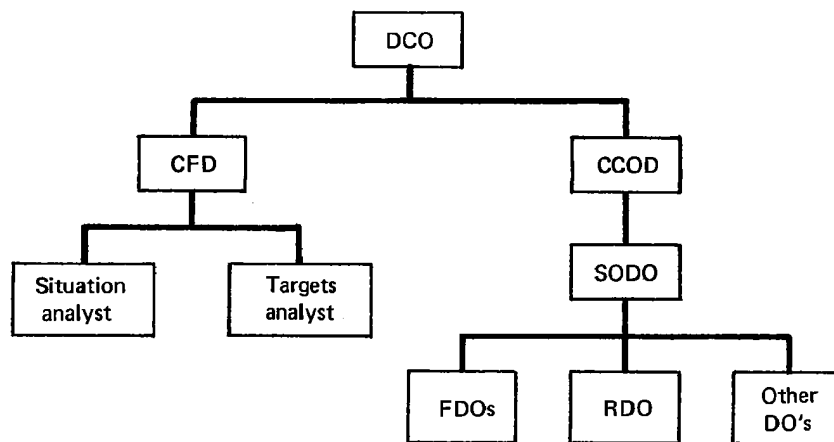

Fig. 3 – Combat Operations Organization



situation by following the incoming message traffic and plotting the movements and positions of enemy forces. He watches for developing threats and initiates a threat warning if the situation warrants one. He passes any traffic relating to potentially lucrative or important targets to the targets analyst, who subjects them to further analysis as potential strike recommendations to the Operations Division. The Chief of Fusion Division oversees the fusion operation and approves transmission of strike recommendations to Operations.

Although Combat Operations is often described as the entity that manages "today's war," its charter actually is not as broad as that description might indicate. Though it does have responsibility for overseeing the management of all tactical air resources, detailed decisions regarding the employment of some of those resources are made in other facilities. Forces assigned to support the engaged ground forces are managed principally through the ASOC and the joint Army/Air Force system for managing close air support. Defensive counter-air operations are run primarily through the CRC, the TACS element having the radar coverage which provides the continuing air picture and the communications necessary to manage the defensive air battle. Combat Operations has the principal decisionmaking responsibility for two air battle missions: interdiction and offensive counter air. Interdiction includes strikes against fixed targets in enemy territory, and against enemy rear echelon forces or forces moving toward the front. Offensive counter air includes strikes against enemy bases or other rear elements of the enemy's tactical air forces.

Some feeling for the physical layout of a TACC Combat Operations section and the complexity of the activity taking place there can be obtained from Fig. 4, which shows the Current Operations (as it was then called) layout from the GALLANT EAGLE Exercise held at Eglin Air Force Base, Florida, in October 1978. The elements across the top and sides are status boards and map displays, and the elements within the diagram and across the bottom are personnel positions. The figure shows the large number of positions and functions involved in running Combat Operations, and gives some idea of the many and varied displays that support the activity.

#### COMMAND AND CONTROL AS PERCEIVING AND DECIDING

The command and control system is the nervous system of a military combat organization, performing those functions for that military organization that the nervous system performs for a living organism. At a very abstract level these consist of two primary activities-- perceiving and deciding. The total situation must be perceived and understood, and the threats and opportunities it provides assessed. Actions must then be chosen, within the constraints of the available capabilities, to meet those threats and exploit the opportunities the evolving situation presents. In principle, if both these activities took place on a continuing up-to-the-minute basis, the necessary feedback loops to continue the process would be automatic. Changes in the situation, including those resulting from the actions taken, would feed back into the perception process and, in turn, produce decisions to modify previous decisions and select new actions in response to those changes.

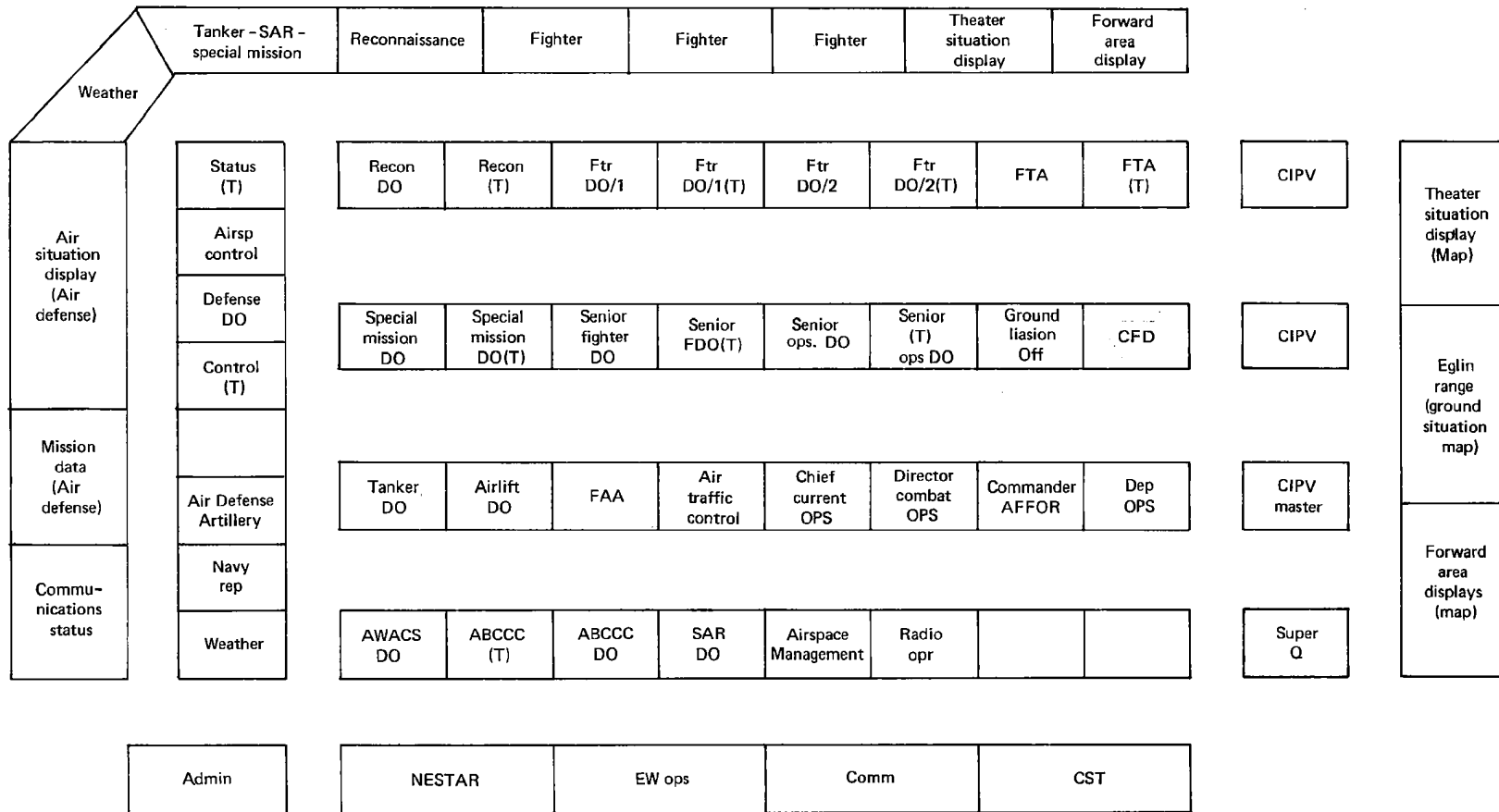

Fig. 4 – TACC Current Operations Arrangement for GALLANT EAGLE '78

In practice, however, this conceptually simple process becomes more complicated. The process takes place within a complex organizational structure with multiple echelons of command and divided responsibilities within each of those echelons. The primary activities of perceiving and deciding are fragmented and scattered across that structure in accordance with these divisions. Each of the organizations and facilities involved, from the National Command Authority at the top to the TACC and the TACS elements below it, constructs its own perception of the conflict and makes decisions on the basis of that perception. Even the distinction between perceiving and deciding becomes blurred. Many decisions are made as part of the perception developing process, and decisions made at one place become part of the perceptions which are constructed at others.

These complexities are unavoidable, given the scope of large scale military conflict and the size of the military organization necessary to deal with it. But they introduce complications and difficulties not suggested by our simple abstraction of command and control as a process of perception and decision. No single element has more than a fraction of the total information available to the whole, and mechanisms must be provided for communicating necessary information throughout the structure. Each action "chosen" by the organization as a whole results from many smaller decisions taken by elements of the organization, based in turn on their own restricted perceptions of the situation and their own responsibilities within the organization.

At the higher echelons, decisions generally involve large scale resource allocations to subordinates and guidance and direction to the echelons below, which become more specific as they move down the chain of command. It is generally only at the level of the TACC that the actions taken become concrete, in the sense that weapons are assigned to specific targets. (We say "generally" here because there are likely to be exceptions--such as specific, critical targets selected at higher echelons.)

Perceptions flow up and down the chain, with juniors reporting information upward to seniors and seniors sharing their views of the situation with their juniors. In the past, lower echelons were the principal source of information for those above them, and the flow of the detailed information on which perceptions of the battle are based was predominately upwards. More recently, however, with the advent of increasingly capable intelligence-gathering assets controlled and directed at a national level, that flow is becoming more bi-directional.

All these activities take time, as does the process of communication and coordination between the various organizational elements involved. This means that plans must be made ahead of time, and actions taken to support those plans begun well before the plans are actually to be executed. Whereas an elementary view of perceiving and deciding effectively ignores the time dimension, in reality time has significant effects. Different echelons in the command and control (C<sup>2</sup>) system operate on different time scales, with activities becoming more nearly "real time" at lower echelons closer to the combat operations.

Our simple abstraction of perception and decision can be enriched by a crosscutting time dimension as shown in Fig. 5. Think of time as measured relative to the time that a particular action will be taken. Some of the deciding activity associated with that action takes place in advance, based on perceptions at that time of what the situation will be when the decision is implemented. We will call this activity preplanning. As the decision is implemented and the preplanned action is executed, the action and its effects are monitored and decisions are made to continue the action as planned or to redirect it as necessary. We will call this activity controlling.

All echelons are involved in both preplanning and controlling. Even if the decisions made at a particular echelon consist principally of guidance to a subordinate, that guidance is chosen because of a belief that it will affect the war in a particular way. The progress of

	Preplanning	Controlling
Deciding	Advanced choice based on anticipated situation	Decisions to continue or modify action underway
Perceiving	Anticipating situation based on prior info.	Monitoring situation as it unfolds

Fig. 5 – A simple abstract model of C<sup>2</sup> planning and decisionmaking

the war will then be monitored, and if the desired effects are not forthcoming, the guidance is likely to be reconsidered and changed. The specific differences between the preplanning and controlling activities at a particular echelon can be seen best by examining the activities of that echelon in some detail. This we will do only for the TACC.

The operations for which the TACC is responsible involve the application of tactical air power against specific targets in accordance with the guidance received from above. These operations are planned a day in advance by Combat Plans, based on current and anticipated conditions. Then, as the time for the execution approaches, responsibility for monitoring the operations and for redirecting them if necessary to respond to a changed environment shifts to Combat Operations. It is this latter process which will concern us most in this report.

This parallel between preplanning/controlling and Combat Plans/Combat Operations can be seen by comparing Fig. 5, which describes our basic conceptual model, and Fig. 3, which shows the structure of the TACC. The second parallel which appears in that comparison, between operations and decisionmaking on the one hand and intelligence and perception on the other, suggests a separation between perceiving and deciding that is only partially correct in practice. It is true that the principle decisionmaking authority rests with operations, and that intelligence can be usefully thought of as a perceiving activity. But both operations and intelligence perform both deciding and perceiving functions. Intelligence is responsible for identifying and nominating lucrative targets (deciding), as well as for building and maintaining a

picture of the enemy and his activities (perceiving). In addition to its obvious deciding functions, operations is responsible for the ongoing perception of friendly activities and resources. Between them, then, they must form a joint overall perception of the progress of the battle, and use that perception to deal with the battle as it unfolds.



III. COMBAT OPERATIONS DECISIONMAKING

The Combat Operations section of the TACC and the activities that go on there can be seen from different perspectives, each bringing different aspects into sharp focus and relegating others to the background. Combat Operations can be seen as a facility, for example, within which particular groups of people perform particular command and control related activities. It can also be seen as a node in a communications system, receiving inputs from and transmitting outputs to other nodes in the same system. No single view of Combat Operations is "best" in any absolute sense, but one may be more appropriate than another for addressing particular questions or issues. Here we wish to view Combat Operations as a decisionmaking entity which monitors the progress of an ongoing air war and makes decisions about continuing or modifying previously planned operations in the light of what occurs.

We thus want to identify the important activities involved in this process and to understand the relationships between them. We are not concerned with the exact descriptions of what is done at each position. Rather we want to create an abstract view of the overall decision-making process which will capture the essence of Combat Operations decisionmaking, whether it is done in one place or several, at different operational levels or kinds of control facilities. In sum, we want to capture an overall notion of what is going on.

WHAT DO THEY DO NOW?

One obvious way to start studying Combat Operations decisionmaking is by looking at the existing process and seeing how it is currently performed--by trying to answer the question "What do they do now?" That approach is useful, and is one we have followed. But it has severe practical limitations which are worth some discussion at this point. The principal difficulty is that there is no "they," and there is no "now." There is no operating Tactical Air Control System in peacetime--no TACC, no Combat Operations section with an ongoing day to day function which can be carefully studied to see what it is that "they" do "now" in the kind of detail and precision which people often have in mind when they ask that question.

There are, of course, existing TACCs, in the sense that there are Tactical Air Control Center Squadrons (TACCSS) and Tactical Intelligence Squadrons (TISs) which have the organizational structure, equipment, and the cadre personnel who would man the TACC in the event of a conflict. There are regulations, directives, and studies of various kinds which describe in considerable detail how different elements of that structure should function in combat. And there are training and evaluation exercises in which a TACC, or some parts of it, are used.

But the TACC is a combat organization, an entity in waiting for conflict. Studies, regulations, and directives describe concepts of how the TACC should function, but the differences between how organizations function on paper and in actuality are often large. Exercises provide valuable insight and experience into what combat operations might be

like, but that experience is necessarily somewhat artificial because the exercise environment is itself artificial.<sup>1</sup>

Different exercises, in fact, are artificial in different ways, and with different implications for the lessons that might be drawn from them. Some are field training exercises (FTXs) involving live forces--troops and aircraft--while others are principally command post exercises (CPXs) in which most or all of the combat forces are simulated. Each type has its own advantages and limitations.

Field training exercises provide greater realism than CPXs in some ways, but less in others. They provide an opportunity for the TACS to direct real forces which is not present in CPXs, thus providing the kind of realistic unpredictability which can only be achieved in this way. At the same time, the size of the forces involved and the geographic area over which the exercise is played usually fall far short of what might be expected in a major combat contingency. Safety considerations and the range facilities and airspace available necessarily restrict the degree of realism attainable. From an intelligence point of view, the fictitious geomilitary context within which most live exercises are played (e.g., Country Blue fighting Country Orange in North Carolina) imposes a major artificiality.

Command Post Exercises like Blue Flag provide an opportunity for larger forces to be controlled over a wider area and with a far more realistic intelligence data base and geomilitary context (e.g., NATO vs.

---

<sup>1</sup>This artificiality necessarily has effects on the findings of any research--ours included--which is based heavily on exercise observations. We believe, though we can never guarantee, that those effects do not invalidate our findings.

Warsaw Pact), but with other limitations that arise when all exercise feedback comes from a heavily burdened control team. The only way the control team can manage the volume of communications required by such an exercise is by sticking closely to a previously prepared script. As a result, the amount of free play possible is severely limited, so that the effects which the decisions made by the players can have on the course of the "war" are minimal.

This reduces the incentives the players have to try to make a difference, since they know that what happens will not be affected much by what they do. Combat Operations decisionmaking becomes largely routine, with ad hoc decisions to allocate available resources made as the need for those decisions arise. Far less attention is given to what overall effect the pattern of decisions made has on the course of the battle, or to how the individual decisions relate to the COMTAF's overall battle plan (if, indeed, he has one) than would presumably be the case in a real war with real outcomes at stake.

Since the TACC is a decisionmaking organization, this artificiality naturally has a substantial effect on some aspects of its performance. In such circumstances, it is often hard to provide a stimulating environment for decisionmaking. As a consequence, only limited observation of the decisionmaking aspects of a TACC can be gained from CPXs.

The problem of understanding "what they do now" is further complicated by the fact that the U.S. Air Force is a major player in not just one tactical air command and control system, but in three. These include the deployable TACS around which this Note is focused, the NATO

ACCS in Europe, and the Korean TACS. When these are simulated in exercises in the United States, as in a Blue Flag exercise, the further artificiality is introduced of simulating a combined command structure using mainly USAF personnel.

Added to this is the fact that the doctrine and concepts of operation in tactical command and control are in a continual state of development and flux. Conceptual, doctrinal, and procedural issues are under study and debate on an ongoing basis. Different TACCSs and TISs do things differently, and each is continually experimenting and trying new things. Official published doctrine tends to lag rather than lead what operating personnel in the field are doing. All this is as it should be, indeed must be, in a highly uncertain field in which success depends heavily on the skill and insight of the practitioners involved, and tactical command and control certainly is such a field. But it does make it difficult to provide a concise and well defined answer to the deceptively simple question of "What do they do now?"

This does not imply, of course, that nothing can be said on the subject. Much can, and this Note is an attempt to say some of it. But it is important to recognize the difficulty in trying to define the problem too precisely or in trying to characterize Combat Operations decisionmaking on the basis of existing exercise practice or doctrine with the precision with which one could characterize, say, civilian air traffic control decisionmaking using corresponding sources of information.

In what follows we will try to characterize Combat Operations decisionmaking in a fairly broad and general way, and avoid getting too

caught up in details. We recognize that others may have different views about this process; and we hope to stimulate useful discussion and debate on that subject.

#### COMBAT OPERATIONS AS A DECISIONMAKING ENTITY

Combat Operations is a decisionmaking entity. Information comes in which describes the state of the world, including enemy and friendly forces, the current situation, the air resources available to deal with that situation, and the current plans (the ATO) for employing those resources. Decisions are made concerning the ongoing use of tactical air power to achieve military objectives. The activity revolves around a (continually evolving) plan for applying air power resources to satisfy changing demands for those resources--demands only partially foreseen when the plan was written. It has two main components: monitoring the execution of the existing plan, and reacting to the changing situation to change that plan as necessary.

Within Combat Operations, many people make decisions. They do so based on the authority of the commander, of course, and some are authorized to make only very minor decisions. But we wish to avoid the view that only commanders make decisions, while lower level personnel limit their decisionmaking to decisions not to act. This is much too simplistic a view to account for the complex and multi-faceted group decisionmaking process that actually occurs in an operating TACC. Important decisions are made at all levels in the process, and there is debate and discussion among those with expertise at various levels to a degree that sometimes makes it difficult to determine who actually made

a particular decision--in the sense that his choice was the one that was pivotal to the action taken. This person will sometimes be the one with the operational authority, the COMTAF or DCO or even the CCOD, depending on the situation. But it may also be someone much lower--a targets analyst or fighter duty officer.

We will use the term "deciders" to refer to the people in Combat Operations who make the operational decisions required to conduct the ongoing air war. We have chosen a plural term to stress the collective nature of the process and the fact that important choices are made by different people in the process, not by a single decisionmaker at the top.

An abstract view of Combat Operations decisionmaking is shown in Fig. 6. The deciders make the required decisions, supported by both Operations and Intelligence information and advice. In terms of our earlier model of command and control, Combat Operations deciders do the deciding based on perceptions provided by Operations and Intelligence.

This figure shows a conceptual model of the functions necessary for Combat Operations decisionmaking, not an organizational description of the TACC Combat Operations section. That it looks very much like such an organizational description, with the DCO at the top doing the decisionmaking and the Tactical Fusion and Combat Operations Divisions underneath supporting him, attests to the close similarity between our conceptual model and the existing organizational structure. There is, however, an important difference. We see the process as having many deciders, all of whom are supported to varying degrees by the Operations and Intelligence processes. (That these deciders are themselves part of

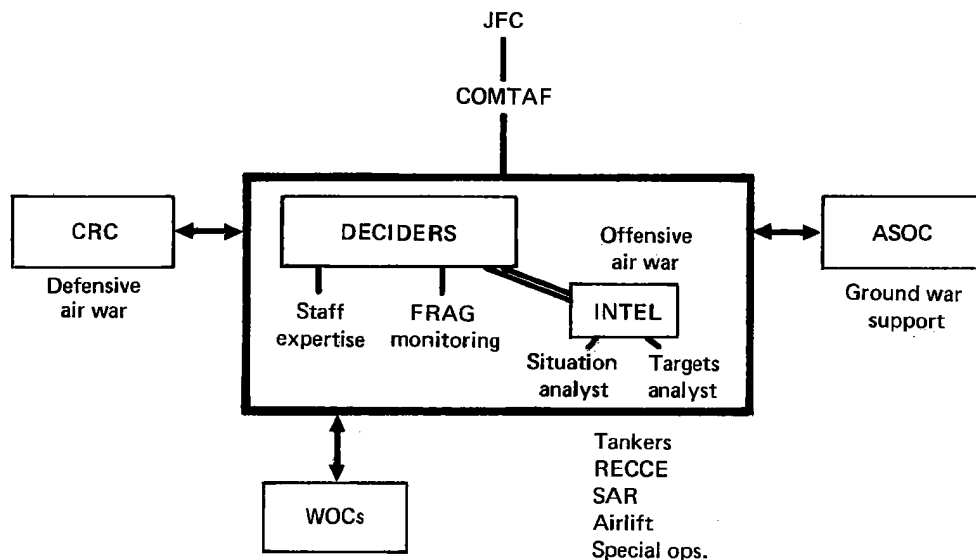

Fig. 6 – An Abstract View of Combat Operations Decisionmaking

one or the other of these processes makes this no less true.)

Combat Operations activities revolve around the ATO and the operations scheduled in it. The missions for the day that were planned the day before are described in the ATO. Display boards show relevant facts, such as take-off time, target, etc. about each of those missions. Some missions involve alert aircraft which deciders can use at their discretion (within certain limits, such as their availability within a particular block of time), but most are preplanned on the assumption that they will be flown as scheduled unless changes are warranted by changing circumstances. Changes to the ATO may come about in response to the discovery of unanticipated targets as the day progresses, or may be brought about by changes in the availability of aircraft--due to



unanticipated maintenance problems, for example, or battle damage sustained by friendly air bases.

Operations follows the flow of events on the friendly side, an activity we will label "ATO monitoring." The main inputs used come from the WOCs, the ASOC, and the CRC. In addition to offensive air operations and reconnaissance, Operations is also concerned with airlift, search and rescue, tanker, and special operations (unconventional warfare). These tasks do not make up a large portion of the activity, and do not play a large role in our model of Combat Operations decisionmaking. Rather, they provide part of the background activity against which the major task of conducting the offensive air war takes place. Operations also provides necessary expertise on the capabilities and limitations of the various kind of aircraft available and on the problems likely to arise in their use.

The monitoring activity goes on continuously to ensure that everything is on track. Aircraft should be taking off. Inflight reports, and other routine message reports should be arriving as scheduled. In a typical Combat Operations facility, most of what the operators spend their time doing is associated with the monitoring function. There is a great deal of use of the telephone in receiving reports from the outside which are then posted on the various display boards around the facility. (We will have more to say later about the communications aspects of this.) Some information does not fit on the display boards, and various ad hoc arrangements are often created to deal with that information. These activities are essential to a good picture of what is currently happening, and a great deal of effort is expended in the handling of routine data.

Intelligence monitors the ongoing combat situation and enemy actions in and movements through the theater. Inputs are received from a variety of sensors and collectors, some of which belong to the Tactical Air Forces and some of which do not. Intelligence also identifies and evaluates potential targets against which strikes should be considered. When Intelligence identifies a potentially serious threat or lucrative target, Operations will attempt to determine, from the information about missions on the display boards and from other information they may have, whether there are aircraft available that can be directed against it. The immediate possibilities are to use alert aircraft if available or to divert a preplanned mission.<sup>2</sup> If there is some aspect of the unfolding situation which it is beyond the authority or or capability of Combat Operations to deal with, consultations with higher authorities may be required.

Combat Operations decisionmaking depends heavily on information received from outside the facility. The maps and display boards at an exercise contain most of what is thought to be important information. (The displays are not always the same in each exercise--an indication of how the processes involved can vary according to individual preference.)

---

<sup>2</sup>Missions which are flown against targets selected by Combat Plans (as contained in the ATO) are called "preplanned" missions, while missions flown against targets uncovered during the course of the battle are called "immediate" missions. Immediate missions may result from the assignment of a target to aircraft which have been placed on alert for that purpose and do not otherwise have a specific target assigned, or they may result from reassigning or diverting preplanned sorties against new higher priority targets. A sortie is said to be "reassigned" if the target is changed while the aircraft is still on the ground, and to be "diverted" if the change takes place after the aircraft is airborne.

The real-time inputs include various reports about missions (take-off, landing, inflight, and mission reports), a variety of intelligence and reconnaissance reports, and inputs from the ASOC (and various ground units if there is a Battlefield Control Element (BCE), a ground force liaison team, is present). These inputs are intended to keep Combat Operations in touch with the immediate course of events that affects its decisions. The information about missions is generally complete down to relatively minor details, while other information may be more or less complete.

In addition to the real-time inputs, a variety of other information changes less rapidly. Much seems to be available only through the memory of some of those in Combat Operations, rather than being recorded in any formal way. There is information about the resources available. This is mainly contained in the ATO, but also includes some logistics planning factors, such as the time it takes to turn (refuel and rearm) a particular type of aircraft at a given base. The plans for the day from the Joint Forces Commander, the COMTAF, and various ground forces should be available (but in exercises these often do not seem to be an essential part of the decision process within Combat Operations). Other data include information about the aircraft and munitions available, weather, the geography and demography of the area of the war, and miscellaneous "encyclopedic" information of a general nature that might occasionally be useful to Combat Operations' decisionmaking. And beyond all this, but an important information source which should not be neglected, is the background and experience of the personnel manning Combat Operations, and the expertise they bring to bear on the problems facing them.

Many people play significant decisionmaking roles in the TACC, acting as "deciders" in the sense of our model. These include the COMTAF and DCO at the top, the targets analyst and FDO at the bottom, and people in between such as the CCOD and CFD. Actual decisionmaking patterns in exercises depend on the personalities and decision styles of the individuals involved, and we would expect to find similar variabilities in Combat Operations' decisionmaking in combat.

Some commanders and DCOs will pay very close attention to the detailed flow of the air war and will make most of the detailed operational decisions personally, while others will leave most of the decisionmaking to subordinates and will limit their own involvement to monitoring and "management by exception." At the lower levels, some FDOs and targets analysts (particularly when given encouragement from above) will follow the situation very closely and will take a great deal of initiative in identifying important targets, matching them to available resources (alert aircraft or missions that can be reassigned or diverted), and proposing essentially complete strike packages to their superiors. Others may content themselves with pointing out opportunities to superiors and letting the superiors do the actual decisionmaking. Intermediate levels, such as the CCOD and CFD, may take a very active role in operational decisionmaking, or may function largely as process managers and leave the operational decisionmaking to others above and below them.

The decisionmaking pattern will not be static and fixed, but will vary over time with the events taking place and the demands those events

impose on the various individuals involved. Even if much of the routine deciding takes place at lower levels, there are likely to be particular situations in which higher level decisionmakers take a greater than average interest and involve themselves more deeply than usual.

In exercises one can often observe this shift in decisionmaking patterns when a potentially lucrative situation begins to develop-- deployment of large numbers of enemy aircraft to forward bases in preparation for a major strike against friendly forces, for example. The DCO may begin to follow developments in far greater detail than has generally been his habit, and may become intimately involved in discussions of what is going on, when is the best time to hit them, how, and with what resources. At this point, he may well become the principal decider within the TACC, with others acting to support and flesh out his decisions, even though he normally functions in a mode of monitoring and approving decisions made principally by others.

Combat operations decisionmaking is a human decisionmaking process, not a formal process completely governed by fixed rules and standard operating procedures. As is the case with most human processes, its variability is greater than formal descriptions of the authority and responsibility of the various participants usually recognize. We believe that this variability is a strength, not a weakness, and that it should be explicitly recognized and considered as part of any attempt to understand and improve the Combat Operations decision process.

COMBAT OPERATIONS' DECISIONMAKING AS PART OF A LARGER PROCESS

Combat Operations is a part of a much larger organizational decisionmaking structure, encompassing the TACS and the higher headquarters above it, whose function is to direct the actions of U.S. military forces in combat. This could be most effectively accomplished, one would think, if the structure were to operate in concert, with the various elements aiming consistently toward a common goal. In particular, this would require that Combat Operations decisionmaking be done with a full knowledge and appreciation of the goals and objectives which higher headquarters was trying to achieve, and an understanding of the impact of ongoing Combat Operations activity on the achievement of those goals.

It is not at all clear that this objective is always met. One form of guidance received by the TACC is by message from higher headquarters describing current priorities and objectives. Another, less formal source of guidance is the remarks made by the COMTAF at the daily planning conferences in Combat Plans when the targets and strikes for the following day are briefed. The mechanisms by which this guidance is disseminated to the various Combat Operations' deciders are largely informal, and it is problematic how much it is internalized and how it actually affects the decisions made.

But even within the TACC, the links between Combat Plans and Combat Operations are not what they might be. A great deal of thought and effort goes into the preparation of the ATO. Targets are evaluated and assigned priorities. Weaponeering calculations are made, and strikes assigned to patterns of targets to achieve desired patterns of effects.

The ATO as finally transmitted contains only a small portion of the information and judgment that went into its preparation. Yet it is this transmitted ATO which is the major source of information about the day's operations in Combat Operations, and most of the background which went into the decisions it reflects is lost. A Fighter Duty Officer considering reassignment of a flight from a planned target to one just uncovered, therefore, might be unaware of the rationale behind the selection of that target in the first place. He would thus be operating on a much more limited basis for deciding than if he knew more about what had gone on in Combat Plans the day before.

Another source of uncoordinated activity is the decentralization of missions to the CRC and ASOC. From the point of view of the Joint Task Force Commander, presumably, and of the COMTAF as well, there is one war going on, and all their resources should be used to fight it. Yet by the time one gets down to the level of direct management of airpower by the ASOC, CRC, and Combat Operations section of the TACC, not one war is being fought, but three. The ground support war, fought from the ASOC, includes air tasks that directly support friendly ground forces in contact. The air defense war, fought by the CRC, involves defensive counter air operations and the control of airspace. The offensive air war, fought by Combat Operations, concentrates on interdiction strikes against second and third echelon targets, and offensive counter air strikes against enemy air resources well back from the battle area. These separate facilities must necessarily lose a degree of coordination and integration between the different wars, and cannot retain the one-battle perspective of the Joint Force Commander.

Combat Operations decisionmaking was characterized earlier as revolving around a (continually evolving) plan for applying air power resources to satisfy changing demands for those resources. The evolution of that plan should thus take into account probable future demands and resources, i.e., should look ahead at the evolving war, and should also take account of the planning processes and requirements of other related organizations in a systematic manner. Unfortunately, when observing Combat Operations decisionmaking during exercises, one does not get the feeling that a great deal of this is going on. Rather, what seems to be happening is a series of ad hoc decisions driven by the events of the moment--to divert this strike mission against that target because it seems like a reasonable thing to do at the time, etc.

Each decision has the character of a local "this looks best right now" decision that takes into account only part of the information that might influence it. In a manual system, with its heavy load of routine information handling, this is probably all that can be done most of the time. The time available for each individual decision is short, and there are few tools to assist the deciders. In general, they must make a quick decision about each new target. Such decisions are difficult to balance against potential later needs. Even the physical arrangement of the facility itself is not well suited to coordinated planning. One often observes awkward conferences being held in the narrow aisles between the rows of desks which face the display boards. It is clear that group planning was not envisioned in the design of the TACC facilities.



Another factor influencing the process is the (at least implicit) presence of management criteria which may relate only indirectly to combat effectiveness. To the extent that decisions are affected by such influences, combat effectiveness may suffer in situations in which those criteria turn out to be inappropriate. One such criterion, for example, is the maintenance of a high sortie rate. All other things being equal, a higher sortie rate usually implies higher combat effectiveness. But all other things are not always equal. The highest sortie rates can usually be achieved by spreading sorties out uniformly during the day, and bunching sorties to provide surge capability usually decreases the number available. Too much emphasis on a high sortie rate, per se, could distort the decisionmaking process in circumstances in which a short term surge capability might be worth more than a high sortie rate.

There is another, and perhaps more fundamental, level on which these various issues of coherence can be considered. We have been discussing the TACS as a distributed organizational decisionmaking system in which various elements have responsibility for particular choices, and their combined overall activity leads to the actions of the organization as a whole. This is the way command and control is generally viewed today, but there is a different view of command and control--indeed of warfare itself--which deserves some mention. This view sees warfare as a more personal contest between opposing commanders--the analogy with chess is sometimes used--in which each is pitted against the other with the forces at his disposal. Each attempts to achieve victory not through sheer military strength alone but through a combination of better strategy, better tactics, surprise and deception, etc.

The appropriate role of the command and control system under such a view of warfare would be to act as an extension of the commander, to put his concept of action into practice and to keep him informed of its progress. To do this the various deciders throughout the system need to understand what he is trying to do and to act accordingly. This may call for very different actions than would be appropriate under the more conventional view. In general, creating and supporting a command and control system in this image is probably a far more difficult task than doing so in the more conventional image, but it may be well worth the effort. We will not elaborate on this point, but we raise it here because it is important and should receive greater attention. It should be considered in the development of automated support for the TACS, because the nature of such support should reflect the nature of the command and control system being supported.

Combat Operations is basically a resource management organization devoted to applying available resources to a rapidly changing situation. Increasingly larger volumes of information are being made available for this purpose, both from continually improving (though still insufficient) communications capabilities, and from more and better battlefield sensors. With more information available, better decisions may be possible. But for this to come about, that information must be accessible and usable. There has been a great deal of emphasis on information that bears on the disposition and activities of the opposing forces. Sensors are improving, and techniques are being developed to enable the information they produce to be used rapidly to improve the

understanding of the situation. The concomitant development in decisionmaking procedures and approaches has yet to take place.

Relatively little attention has been paid to the collection and use of information about friendly forces, and one aspect (logistics) has been almost completely ignored at the level of Combat Operations. In CPXs and other exercises, only a crude picture of the disposition and activities of friendly ground forces is usually maintained in Combat Operations. This is in part because the direct responsibility for air support of the ground forces resides with the ASOC, whereas Combat Operations retains direct management only of air resources attacking targets well beyond friendly forces. Nevertheless, Combat Operations does retain overall cognizance, on behalf of the COMTAF, of the full range of tactical air operations, and therefore should have an incentive to be attentive to the full combat picture.

Combat Operations planning and coordination with the sources of supply of air resources is also lacking. The ATO sometimes seems to be taken as the complete statement of the resources that are available for the day, with the only possibilities of doing anything other than what was decided the day before being to divert an already available mission, or use an alert aircraft (again, made available through a decision made the previous day). The separation of the logistics process from operations appears to be quite complete, and the notion that a base might deliver more aircraft, or on a different schedule, is seldom entertained. However, in a dynamic war it is unlikely that mission requirements can always be accurately foreseen a day in advance. Bases have considerable capacity to respond to emergency situations, as

demonstrated in the recent USAFE Salty Rooster exercise to explore surge capabilities. While one expects that in an actual combat situation Combat Operations decisionmakers would find out about additional resources if they were needed in a critical situation, some attention to preparing procedures and training for this resource management problem seems warranted.

Our observations concerning Combat Operations decisionmaking convince us that further analysis of many facets of this process is needed. The current system was designed in a way which we think is incompatible with the requirements for managing Combat Operations today and in the future. In a highly dynamic war with large amounts of detailed real time information available, new means of analyzing the current situation and new modes of decisionmaking and planning appear to be essential if we are to fully exploit the capabilities of current and emerging weapon systems and sensors.

Of course real combat will be different in many ways from exercises. Our conclusions are based in part on observation of exercises, and we recognize that men and institutions adapt, and often find solutions to problems when they arise in practice that were not considered in advance. But the system as described in regulations and observed in exercises is the one that will be used initially, until its operations are reshaped by the environment of a particular conflict. The problem with adaptive learning is that it will take time. This may be exceedingly expensive, if not catastrophic, in a highly dynamic and fast-paced conflict.

#### IV. AUTOMATION OF COMBAT OPERATIONS DECISIONMAKING

Many (though of course not all) of the impediments to better Combat Operations decisionmaking are information related. There is too much information, changing too rapidly, for deciders to assimilate and effectively utilize. The problem is worsening as new information collection and communications systems add to the already overwhelming flow. One solution would be to add more people. This is impractical for a number of reasons, not the least of which is the internal communications problem. As more people become involved in a group decisionmaking activity, more time and effort must be spent on communications within the group and less on the actual problems at hand. The current TACC is probably already at a reasonable upper manning limit.

One possible solution is to automate some of the functions currently performed manually, to use computers to perform some of the routine information handling and communications and thus increase the productivity of the personnel. This avenue is quite attractive, and a number of programs are under way to provide automated support for various portions of the TACS. In this section we shall identify and briefly explore some of the issues raised by the automation of Combat Operations functions.

The TACS is an evolutionary system. It has evolved under a variety of pressures--institutional and political as well as technological and operational--into what it is today, and it will continue to evolve in the future. Sudden revolutionary change is unlikely to be either

possible or desirable. Whatever the TACS and its various elements become in the future will have strong roots in what they now are. Gradual evolutionary change, dealing with a few issues at a time, making changes, seeing how they work, and repeating the process, is probably a better route to improvement than the superficially more efficient and attractive route of total system redesign.

The evolution of the TACS involves doctrine, concepts, and procedures. Ideas concerning how the TACS should be organized and operated to achieve effective use of air power in a theater conflict are constantly changing, driven by new weapons systems, the changing threat, new tactical ideas, etc. Of course, computer technology is evolving rapidly, too, but that may be less important than the non-computer evolution. While "evolutionary development" is becoming a buzz-word to be applied to the process of adding automation to the TACC (as to so much else of the C<sup>2</sup> world), we wish to emphasize that the hard part of this is to adapt the automation to the evolving world of command and control, not to keep pace with the latest developments in computers.

The potential utility of automation in the TACC is clear. An ever larger amount of data, from an increasingly large and productive array of sensors, is becoming available under circumstances in which it must be used rapidly. Digital technology and automation are the only means of distributing this information rapidly, storing it, and using it quickly. But this means evolving new concepts concerning how to do it, and understanding the impact of putting information formerly handled manually in a form for manipulation through and by a computer. The computer technology per se is not likely to be the pacing factor, so

much as the understanding of what needs to be done, and of how to do it in a way that meets the needs of those who use it. A real understanding of how to use computer technology to make the TACC more effective may be quite difficult, and may require many evolutionary iterations.

#### ORGANIZATIONAL IMPACTS

The organizational structure of the TACC and of the larger TACS has evolved to what it is today as the result of a many influences. Not the least of these has been the inherent information processing, management, and decisionmaking capabilities of the various elements which make it up. Part of the reason for the present split between Combat Plans and Combat Operations, for example, lies with the inherent slowness of the planning process and resultant need to do it far enough in advance to get the aircraft ready to fly planned missions. Part of the reason for the split between the Tactical Fusion Division in Combat Operations and the Combat Operations Intelligence Division (COID) in Combat Plans, and the inherent duplication of effort that this split entails, lies with the fact that the routine processing of incoming intelligence by the COID was not fast enough to be responsive to the needs of Combat Operations.

But as automated support systems are introduced into the TACS, the capabilities (both relative and absolute) of the various elements making up the TACS will change. Pressures that now make the existing organizational structure valid and rational will be replaced by new pressures that will push the structure in new directions. It might be possible, for example, to develop a process in which preplanning is much

more directed at making resources available for the next day's use, but in which only a minimum number of targets are actually assigned the day before. On the intelligence side, a common data base, updated on a near-real-time basis, might serve both the planning and operations functions, resulting in a reintegration of what are now largely separate activities.

It is not our purpose here to recommend specific changes to the current system. Rather we want to point out that with the introduction of automation and the availability of large amounts of near-real-time information from sensors (which may require new kinds of decisionmaking and planning), the pressures that influence organizational structure will change, and the structure should be ready to change with it. It would be a major mistake simply to automate current functions without attempting to anticipate changes. At the same time, it would be equally foolhardy to try to fully anticipate them and to design a brand new automated TACS in a single sweep. Considerations of organizational structure and change provide another set of strong arguments for the gradual evolutionary approach to the automation of tactical command and control.

#### INFORMATION MANAGEMENT

The large amounts of information needed to direct an ongoing air war impose a requirement for ways to manage that information--to store, display, update, and analyze it as necessary and to purge it when it is no longer needed. In the existing TACC, the major mechanisms for managing information are the displays themselves--the greaseboards and



clutter maps that line the walls. They serve as information storage as well as display media, and are continuously updated as new information is received. Analysis is left to the personnel on the floor. The purging problem is solved by the limited storage capacity of the boards--old information must be removed as the boards are filled to make room for new.

Though they have proved their value over time, the greaseboards are a clumsy and inefficient storage and display medium. The whole data base is continuously displayed, always in the same form, so that a user who needs particular items of information arrayed in a different form must sort that information out and arrange it for himself. Indeed, in operating TACCs one finds a variety of ad hoc personal information systems in the form of scraps of paper containing personalized summaries various individuals find useful, but hard to glean directly from the boards. Updating the boards is slow and manpower intensive--done manually by plotters with grease pencils. This is related to the single storage/display medium. There can be only one copy, arranged in a fixed format, because it is so very slow and difficult to change. Even the physical layout of the TACC is significantly influenced by this storage/display medium, in that the facility must be large enough to accommodate the boards, and arranged so that they are visible to all who need to use the information they contain.

The way in which information is displayed and managed cannot help but constrain the perceptions and decisions coming out of Combat Operations. The data on the boards are the primary data on which decisions concerning immediate missions are made. With present

limitations on space for the display of information in Combat Operations, it is evident that decisions must be made on the basis of only part of the relevant information. This is confirmed by exercise observations.

Automated information systems for the TACC could remove many of these limitations. They could provide access to much more information than is now displayed at any one time, and different computer-generated displays could be tailored to the needs of different users. Updating could be easier, and perhaps even be made automatic for some classes of information. The single large display could be replaced by numerous smaller displays, allowing for a wider variety of facility configurations.

This will necessitate hard looks at a number of information management issues which more or less take care of themselves at present. What kinds of information should be kept, and for how long? What subsets of that information should be displayed, to whom, and in what formats? What kinds of indices and cueing methods are required for the backup information not continuously on display? And for that matter, what kinds of automatic advisories should be generated regarding information that is displayed, but perhaps not noticed when it should be (an overdue aircraft, for example)?

#### COMMUNICATIONS

The TACC and the TACS as a whole are heavily dependent on voice communication--radios and telephones. Most of the inputs to the operations side of Combat Operations, and a substantial portion of the

intelligence input, come through voice channels. These channels provide duplex communications, i.e., communication in both directions simultaneously. This is needed at times, as when the FDO at the TACC is discussing aircraft availability with a WOC; but much of the information coming into the TACC needs only a simplex channel (i.e., a channel with only one direction). In addition, this information often requires much less bandwidth than voice circuits utilize. The majority of the routine data used for monitoring ongoing activities, such as takeoff and inflight reports, fall in this category.

For duplex communication requiring a direct interchange of ideas between two people, voice communication is highly desirable and probably outperforms by a wide margin alternatives such as conversational teletype. A duplex voice circuit is highly reliable, if used intelligently. The speakers can deal with transmission problems in a variety of ways, and can communicate successfully under circumstances that would be very difficult otherwise. People often find it easier to express themselves and to understand each other using voice communications where there is some uncertainty or emotional content to the information being exchanged. (For instance, it is easier to communicate a sense of urgency by voice.) Voice communications have historically been very rapid compared with alternative communications systems (generally involving communications centers which introduce substantial delays). They do suffer from the disadvantage that information is not received in recorded form, so the receiver must take some action to record it and make it available to others when appropriate, but the advantages will generally outweigh this where duplex communication is required.

Speed and reliability advantages have made voice circuits the communications medium of choice for simplex as well as duplex communications between the TACC and other TACS elements in the past. For routine traffic such as takeoff reports, however, this is a very expensive and inefficient means of communication. It makes very inefficient use of scarce voice channels, merely for the sake of getting routine traffic through quickly so that the occasional non-routine bit of information will not be delayed. It is labor-intensive, and indeed may be a major factor in the large manpower requirements of the current TACCs.

As automated support is introduced into the TACS, however, this will no longer be the case. Simplex communication is easy to put into a computer. The advent of good digital communications links should make it possible to transmit messages rapidly between the computers supporting the various TACS elements. And if this is done, much of the present requirement for voice communications circuits, and the people to handle them, will be reduced. Direct user-to-user computer communications can be faster, cheaper, and more reliable than voice. We would expect such communications to replace much of the current simplex voice communications, though the need for duplex voice would of course remain.

#### MANPOWER REQUIREMENTS

A large part of the activity in Combat Operations is devoted to clerical tasks, many of them related to communications requirements that

we have described as "simplex." The possibility exists that the Combat Operations decision process could be carried out by far fewer people than at present, given an adequate level of automated clerical and decisionmaking support. The advantages of this might go far beyond the rather limited manpower savings, in that a smaller, more cohesive group might be able to manage the air war far better than does the large group currently trying to do it. With fewer people in the facility, communications among them would be easier and key people would be better able to keep track of what is going on. Routine tasks would be handled by the computer, eliminating some of the repetitive and boring detail now required, and providing personnel with more direct and challenging involvement in the "action," hence with more incentive to care and to do a good job.

At the same time, major reductions in Combat Operations manning might also have potential drawbacks. The most obvious place for reductions, beyond the plotter/clerical level, would be in the ranks of the Fighter Duty Officers whose primary monitoring activity is fairly clerical in nature. But these officers, in addition to performing their duties, bring to the TACC a source of expertise in current fighter operations and tactics which may be quite valuable in TACC decisionmaking. Any consideration of reduced manning of Combat Operations should take the need for this expertise into account.

The introduction of automation into Combat Operations and the TACS in general has the potential to assist and significantly enhance the human decisionmaking processes which take place there. However, care must be taken to ensure that at the same time additional capabilities

are made available through computers, current capabilities are not diminished. The current manual system of updating the display boards in order to keep a current picture of the use of air resources may have the positive benefit of keeping the Combat Operations staff aware of the situation in a way which might not occur if no one were actively involved in maintaining the data. The fact that important data have been received by a computer and the data base has been updated does not mean that the person responsible for dealing with the data is aware of it. Of course, even in the current system those who must make decisions that may be driven by incoming data are not necessarily the ones who actually participate in updating the data bases (changing the display boards). Nevertheless, care must be taken to ensure that the automated system and the procedures used with it actually result in an accurate awareness of the current situation on the part of the decisionmakers in Combat Operations. Any proposed system should not be implemented until experiments have demonstrated that it can and will be used effectively.

Another set of questions surrounds the issues of vulnerability and reliability. How reliable will the automated system be under combat conditions, and how vulnerable? Will a manual backup be required, and if so, will this negate some of the potential benefits of automation. Will the large display boards and the personnel necessary to maintain them be required as backup, for example? We believe the answer should be "no," and that a highly reliable backup system should be possible using microcomputer technology which would preclude the necessity for a full-blown manual backup. But such a system has not yet been demonstrated, and cannot be taken for granted.

### EVOLUTIONARY DEVELOPMENT

We have presented a conceptual view of TACC Combat Operations and the processes that take place there. We have focused to a degree, but not exclusively, on those aspects that may be affected by automation. We have attempted to make clear our view that while evolution is an essential part of the problem of automating the TACC, it is the overall evolution of the command and control processes themselves, together with the technologies that support them, that should be the focus of attention. The "evolutionary development" of automated systems to support TACC Combat Operations, if pursued in a way that takes current structure and operations as an unchanging given, is not likely to be very successful. As we have noted, it also seems reasonable to expect that the introduction of useful automated support will itself change the processes that are being supported. It is inevitable that new tools bring new ways of dealing with old problems.

We believe that the best way of dealing with change in command and control is to build new systems and try them out. Evolution does not and cannot proceed by means of thought processes alone. But given that evolution will occur, it is important that it occur rapidly and in a way that minimizes cost. Clearly, evolution implies learning from the construction or development of things that do not work well, as part of the process of getting to things that do work well. Such a process, however, appears to us to be a prerequisite to the development of more effective technology to support command and control.

This evolution will be one of both concepts and technology, and the issue is how to manage it effectively. The problems in command and

control are not really problems of developing better technology, but rather of understanding the command and control processes themselves, and how they can be effectively enhanced by technology.





