

~~SECRET~~

INSCOM  
GRILL FLAME  
PROGRAM

SESSION REPORT

CLASSIFIED BY: MSG, DAMI-ISH  
051630Z JUL78  
REVIEW ON: March 2002

NOT RELEASABLE TO FOREIGN NATIONALS

ORCON

GRILL FLAME

~~SECRET~~

This document is made available through the declassification efforts  
and research of John Greenewald, Jr., creator of:

# The Black Vault



The Black Vault is the largest online Freedom of Information Act (FOIA)  
document clearinghouse in the world. The research efforts here are  
responsible for the declassification of hundreds of thousands of pages  
released by the U.S. Government & Military.

**Discover the Truth** at: <http://www.theblackvault.com>

~~SECRET~~

SUMMARY ANALYSIS

REMOTE VIEWING SESSION 869

1. (S/NOFORN) This report documents a remote viewing session conducted in compliance with a request for information.
2. (S/NOFORN) The remote viewer's impressions of the target are provided as raw intelligence data, and as such, have not been subjected to any intermediate analysis, evaluation or collation. Interpretation and use of the information provided is the responsibility of the requestor.
3. (S/NOFORN) The protocol used for this session is detailed in the document GRILL FLAME Protocol, AMSAA Applied Remote Viewing Protocol (S), undated.
4. (S/NOFORN) Following is a transcript of the remote viewer's impressions during the remote viewing session. At TAB A are drawings and narrative by the remote viewer. At TAB B is target cuing information provided the remote viewer.

~~SECRET~~

~~SECRET~~

TRANSCRIPT

REMOTE VIEWING SESSION 869

#66: This will be a remote viewing session for 1400 hours, 3 March 1982.

Continue now to relax, relax and concentrate. Focus your attention now solely and completely on the area on the picture in the sealed envelope I have provided you. Focus now on that area. Move your perceptions through time to the area in the photograph on 1 September 1981. Move your perceptions, your awareness through time to the area in the photograph. Focus now on the area of interest and describe your perceptions to me.

#01: I have view of all intermingled white lines.

#66: Just relax and concentrate and don't report 'till you're ready. Just relax and focus on the target. Relax and concentrate.

#01: I have a gray, gray metal square.

#66: Back up from the target area. Back away from the target area now and look at it in perspective and describe it to me. Relax, focus, concentrate.

#01: ..... ~~an attachment place~~. Keep getting impression of inside, outside.

#66: That's very good. Let's fix on the ground, fix on the ground 20 feet from the outside entrance, 1 September 1981.

PAUSE

#01: I keep getting like an ~~building impression~~.

#66: That's fine. Now, tell me about the entrance to this.

PAUSE

~~SECRET~~

~~SECRET~~

#01: ~~Double, double locks.~~ ✓

#66: Getting too close. Back up.

#01: ~~Keep getting a secured door...~~wall, flat, dark square ✓  
on a white...single entry...no, no windows.

#66: All right. Stop. Face away from the entry and describe the scene to me.....1 September 1981.

#01: See...getting a pattern like fence pattern, ~~road.~~

#66: Closer to you.

#01: Platform road.

#66: Terrain.

#01: It's ~~grass humps.~~ Keep getting a feeling of ...I can't tell if it's backwards or right side out. Getting like slots in the ground or upside down pipe, pan shapes...white walls of concrete on both sides.

#66: Okay. Now, this singular entrance which you described..

#01: Yes.

#66: ...stand right at the entrance, right at the entrance. Now, vertically move up 10 feet facing away from the entrance, and,now your perception is up high 10 feet. Describe the horizon to me.

#01: I'm not getting anything. Just a minute.

#66: Okay, the area between 100 and 200 yards away... the terrain.

PAUSE

#01: I keep getting a split image. I keep getting ~~grass~~ ~~grass~~ and pavement.

#66: Okay. I believe your perceptions to be a winking event. Such things are in the area. I believe your perceptions to be a winking event. However, at this time relax now, relax and concentrate and you will now be permitted to enter this structure you have described. Slowly now, move through the entrance and describe the interior of this area to me, 1 September 1981.

~~SECRET~~

#01: Cold metal...

#66: Slowly, careful, precisely.

#01: OD green, color OD green, gray and black.....  
getting hard metal...some bars, solid some bars...  
keep getting like off-set vertical stacks slanted  
thing...container is wood, rough cut wood, but  
smooth inside...walkways are in between stacks.

#66: Describe stacks.

#01: Not higher than eye level...~~some kind of boxes.~~

#66: Open the boxes and tell me what's inside.

#01: Flash of white...~~powder substance.~~ keep wanting  
to say ~~chemical but not chemical.~~ It's...

#66: Back up in time and describe the opening of the  
box and the discovery that you make as you go in  
through the box. Slowly the raw elements.

#01: Cut, narrow band, pins, wire, wood top, black, plastic  
wrap.

#66: Describe shape.

#01: Canister, cardboard...8 inches tall, round...  
4½ inches diameter, hard metal, cap, there's like a  
cap.

#66: Continue, continue.

#01: Soft powder, hard, hard something, wire...

#66: Stop. Close the carton. Replace the stack. Move  
outside the entrance. Describe when ready.

#01: Okay.

#66: Time movement. 2 September 1981. 3 September 1981,  
4 September 1981, 5 September 1981.

#01: Only difference ~~TRUCK.~~

#66: Describe.

~~SECRET~~



~~SECRET~~

- #01: That's another ~~truck~~. Same truck, I think.  
2½ ton...
- #66: Let's continue....5 September 1981.....
- #01: There are three cartons on ~~truck~~ now. Different  
time...late afternoon...before trucks were in the  
morning.
- #66: All right. Let's move on...6 September 1981.
- #01: Nothing.
- #66: 7 September 1981. \*
- #01: I got the ~~small~~ <sup>truck</sup> again but it's...have trouble with  
whether it's late afternoon or...early morning...  
impression of darkness. \*
- #66: All right. Tell me about the truck.
- #01: View is inside...no, no rear cover...just loose..  
canvas laying...on...more like.. ~~jeep type vehicle~~ ✓  
...
- #66: Activity.
- #01: First impression 3, second impression 5 boxes loaded. ✓
- #66: Personnel.
- #01: ~~Impression 3 but only see 2.~~ ✓
- #66: Describe.
- #01: I'm not getting anything to that.....Third person  
somewhere else. Third person somewhere else with  
~~fourth person~~, but they're different.
- #66: Okay. Stick with me here for a minute. Let's examine  
this particular event of 7 September a little more  
closer. Open your time window so that you perceive  
the jeep like vehicle arriving. Follow me through the  
events as it arrives and what happens. Do this now.

5

~~SECRET~~



- #01: Just arrives, parks, people walk away...one person returns...get a waiting...
- #66: Move on through time now.
- #01: ~~Two other people~~ come with third person not in vehicle. He unsecures a door, he and one vehicle person walk away...going to some small building.
- #66: Okay. Describe what you mean by unsecured door.
- #01: Just get...I don't know. I just. I don't know if it's overlay or not. ~~I keep getting a lock forced.~~ Some bar or something put to the lock..... It's twisted, but I'm not sure if that's...
- #66: I understand it's very late in the session and I can hear from your voice.....
- #01: I just keep getting a mental impression of someone putting a bar through a lock and twisting. It's a combination lock.
- #66: All right. Now.....now that you have watched these events take place here tell me a little bit more about the people.
- #01: I get an impression ~~two are military~~ and ~~two aren't.~~
- #66: What do you mean by military? Describe the raw impressions to me.
- #01: They just.....I'm getting an inside, outside feeling ... It's like ~~two inside, two outside...~~ ~~two familiar~~ with this place, and two not familiar. ~~One is.....~~ got some responsibility with the, with this place, this ~~installation or...this group of...container places.....~~
- #66: Okay. Now, I understand you're having problems with people, now we'll deal with that in a later session. I understand it's late in the session. Let's turn one more time to the vehicle. Tell me about the vehicle.
- #01: It's a....just same size as 3/4 ton...very much like American 3/4 ton. It's got American markings. Keep seeing a black star, camouflage background...I'm also getting an impression of ~~a white, German tag,~~ and I

~~SECRET~~

~~don't...small, square upper left...of black, red,  
down or red, black, brown or...outlined in black...  
white tag.~~ ✓

#66: Read it to me.

#01: ~~Eight, six, two, eight, six three.~~ I don't know ✓  
how that's associated though. I'm losing this  
altogether.

#66: I understand. All right. Now, I have no further  
questions that I wish to ask about this target. However,  
I would like to provide you just another couple of  
minutes, to explore and comment as you see fit.  
Do so now.

PAUSE

#01: I'm not getting, not getting any abnormal feeling about  
this target. It's more like this is a normal  
occurrence type thing. Have an impression that it's  
~~happened more than once, this event, chain of events..~~  
~~...that's all I got.~~

#66: All right. Remembering now from the very first of  
your session those impressions that you've had so that  
you might draw them for me. Let's prepare now to draw  
those impressions that you've had.

(SEE TAB A FOR DRAWING NARRATIVE)

7

~~SECRET~~

**TAB**

~~SECRET~~

REMOTE VIEWING SESSION 869

(DRAWING NARRATIVE)

#01: Page 1 is a very simplistic view of a solid steel door with double locks in some kind of a metal frame. And, I get a feeling of something hard about the face like it might be white concrete or light colored concrete. But, it's definitely in a hump of grass and there's slant walls somewhere. I don't know if they're going down into the ground or coming out of the ground or going over to the ground or...I just get this sensation. It's very much like when you walk down into a service area that you're going to pull a truck over, and you're going to work on the bottom of the truck, you know, when you walk down in this pit.

Page 2 is another view of..with some ~~slant walls~~ of ~~this grassy mound type dump area or storage area, with a road and some concrete walk in front of it.~~

Page 3 is one of the views looking out away from it...is a road with a low..wall of sorts, and chain link fence with some concertina wire across the tops, and high pole type whites. This is just like an open area.

Page 4 is another view looking away from one of these. I see other green, grassy mountains all over these... very, very round...grassy mountains with a road just running through it, and a flat horizon.

Number 5 or...labeled A is the example of the ~~gate or case~~ which are stacked about eye-level inside one of one of these grassy mountain containment areas. I get like wire clips around the edges, metal bands, the exterior of the wood case is very rough. The interior, the first thing you hit is a very heavy, black plastic wrap inside which are cardboard dividers separating these...tube type containers that are made out of hard cardboard, and got some kind of diagonal stripe across them. A lot of OD greens, blacks and gray colors. I get a chemical, but not a chemical feeling. I got a feeling for something white, shinny. The cardboard tube containers are six to eight inches tall, 4½ inches in diameter. Inside the container is some kind of lipstick like tubes which I feel are metal and there's some powder contained near or on it or with it that's fine to coarse ground. Then I get a feeling for some kind of spiral

~~SECRET~~

~~SECRET~~

pattern and wire which is D, labeled D. And, if I had to sum it all up then I would say that this is some kind of a, some kind of a storage area for..... some quasi chemical type devices or something in the containers that are controlled.

#66: Okay. Do you have anything to add? How about drawing me a picture of the markings on the truck and the numbers you read to me.

#01: Yeah. I can do that. I dont know where this German tag is coming from, But it's very possible this German tag has nothing at all to do with the truck, but it might have something to do with the people.

#66: Describe it to me very accurately.

#01: Uh-huh. So, on page 6 what I've drawn is a square diagram of what I perceive is probably a tag or plate and a square on the upper left is black, red and white. Football design upper right. I don't know what that is. It's just something that is there. It's a white tag It's bordered in black, and it has numbers 862, and that 2 may be a 3. I don't know. I was getting both.

#66: Why don't you write down on your little arrow "maybe 3."

#01: Maybe a 3. It's on a jeep like vehicle. I keep seeing a rear of this jeep like vehicle without a cover or back on it. It's just like open with a canvas thrown over the back. This German like tag is what was on this jeep like vehicle for a target dated 7 September '81. That's all I have.

~~SECRET~~

SSR  
START WALLS  
SOMEWHERE?

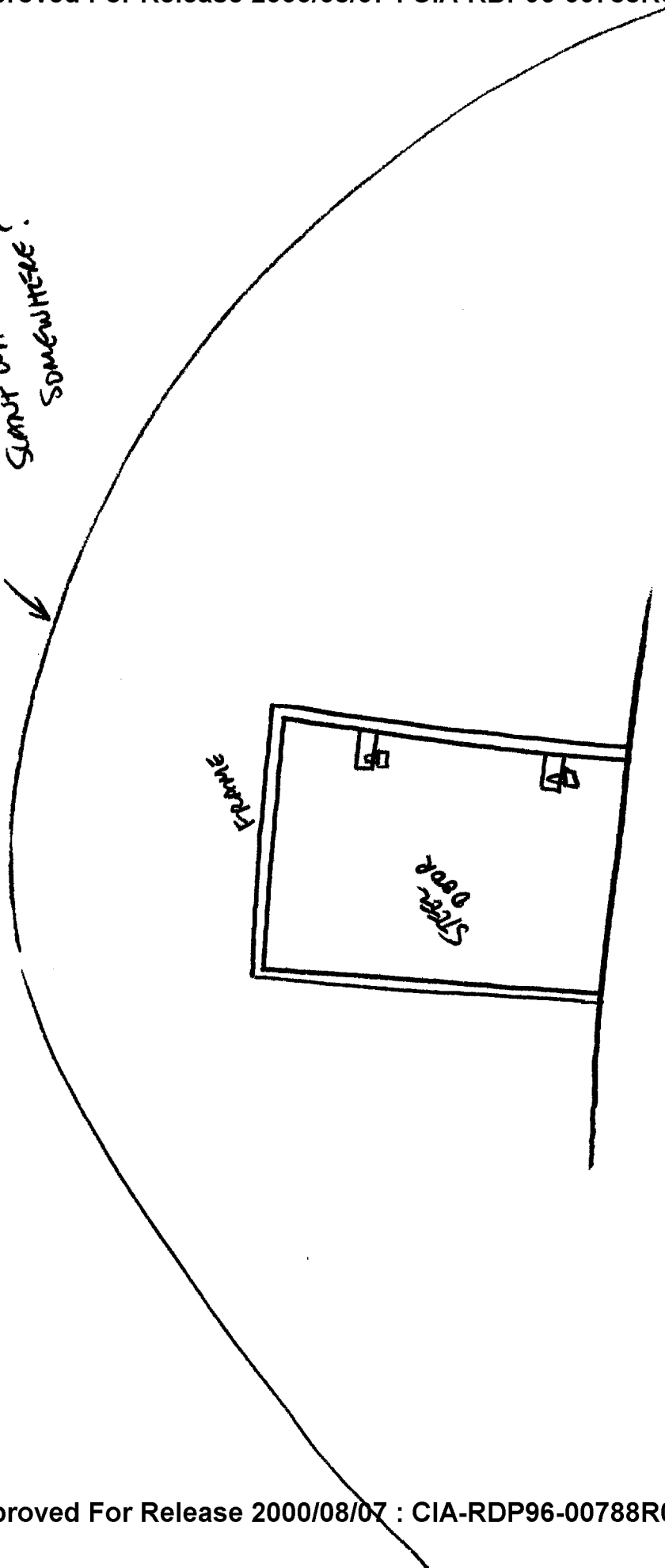

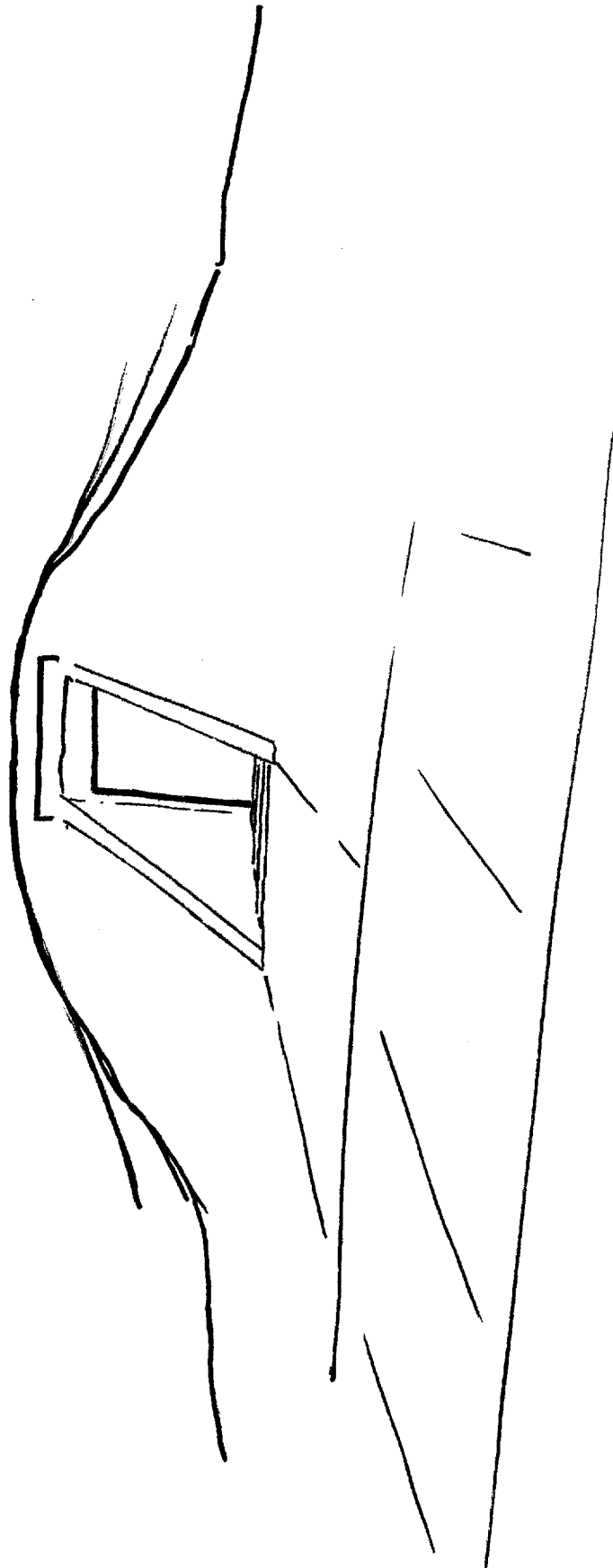

3

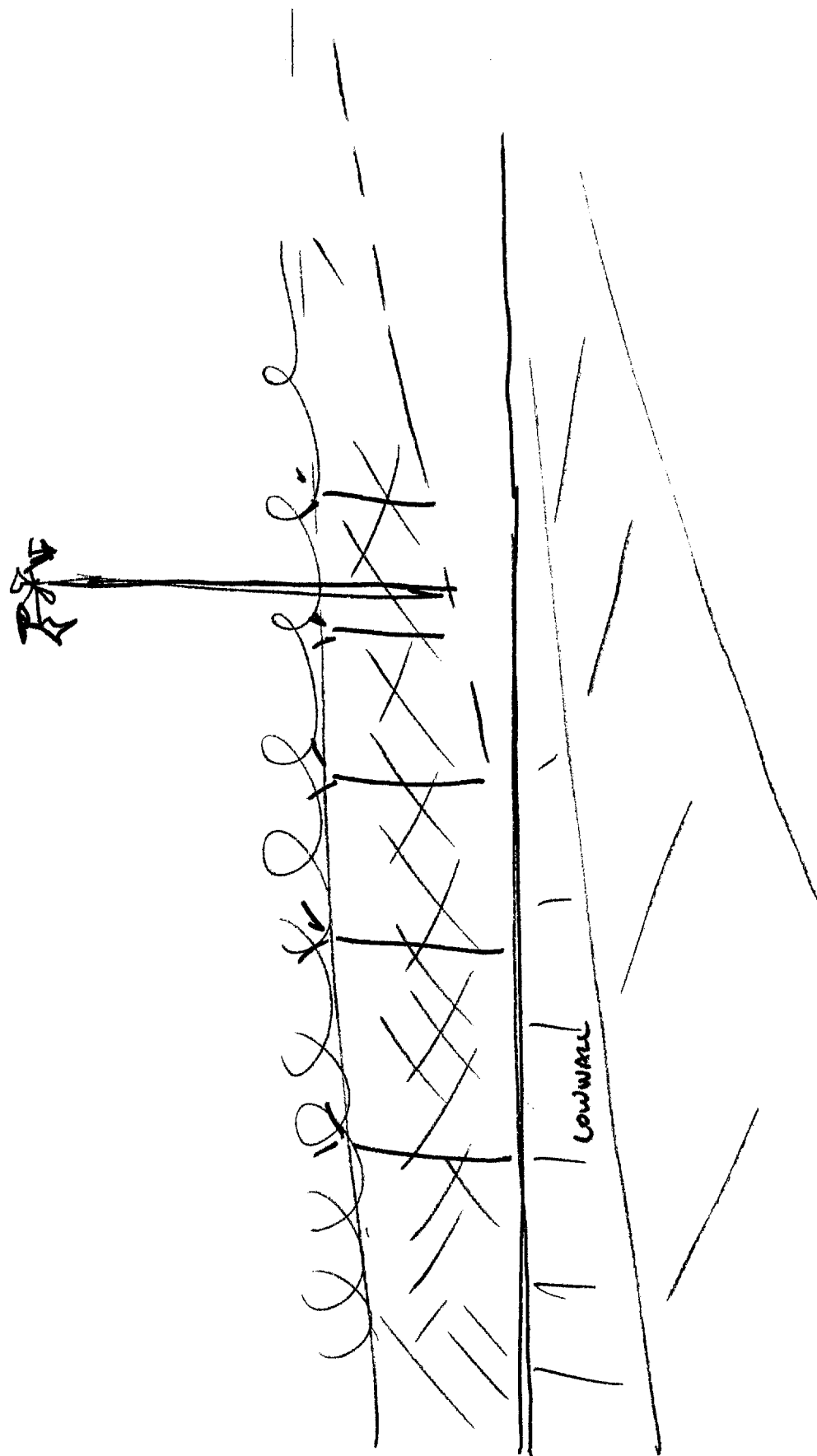



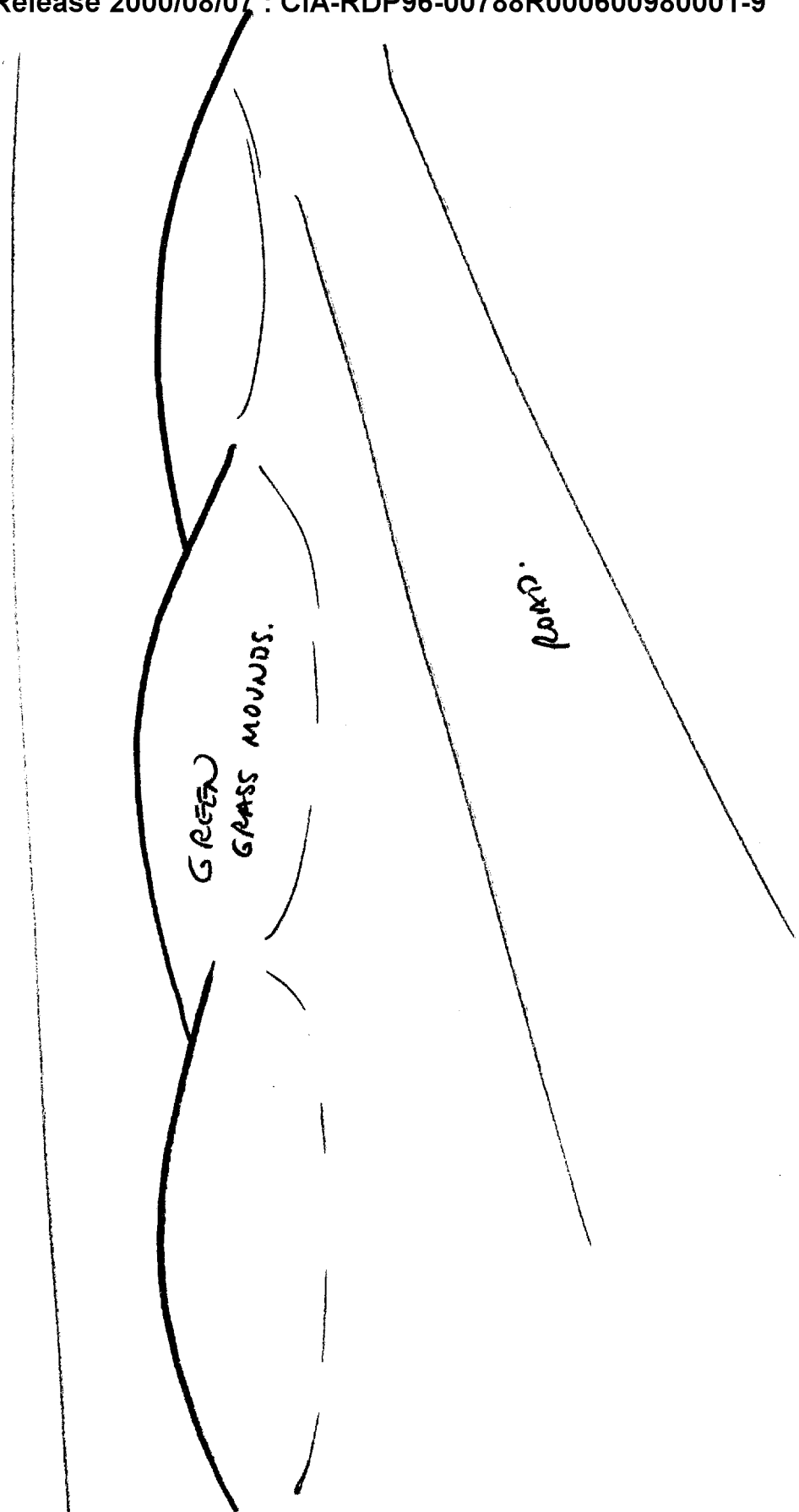

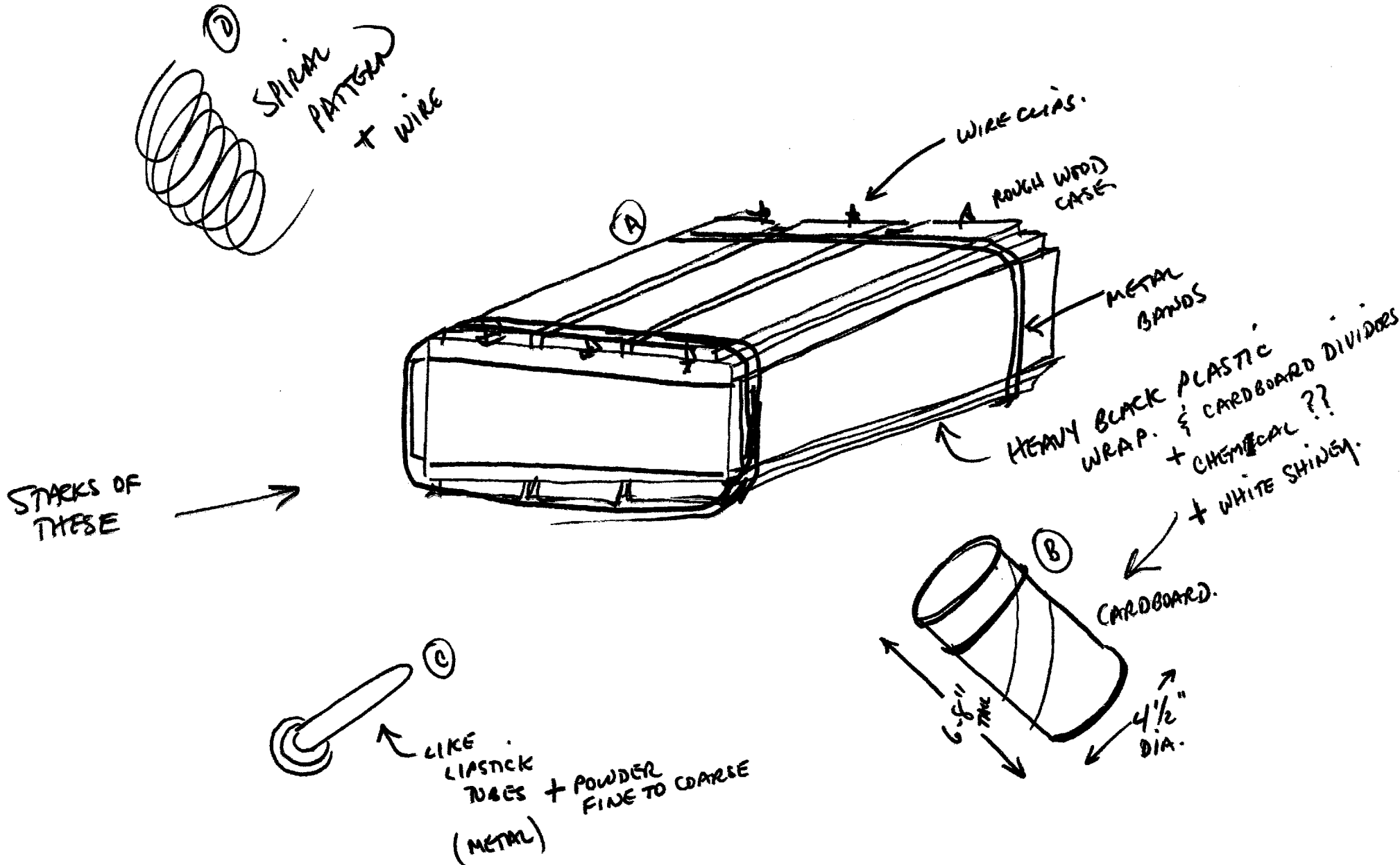

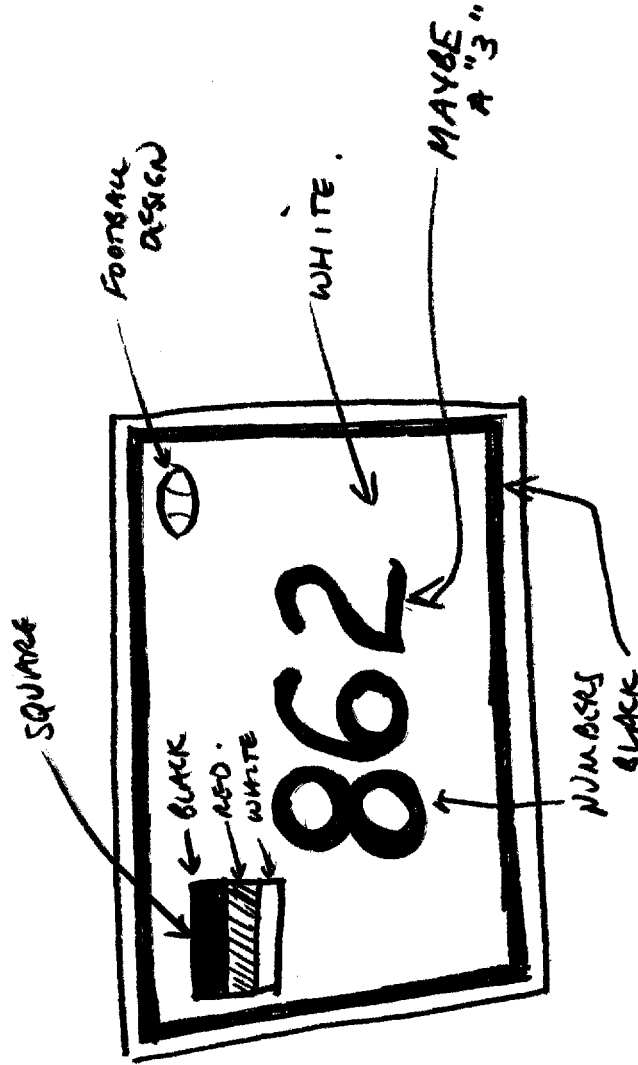

JEEP LIKE  
 VEHICLE MARKING  
 LIKE GERMAN TAC  
 TGT DATE: 07SEP81

**TAB**

~~SECRET~~

TARGET CUING INFORMATION

REMOTE VIEWING SESSION 869

1. (S/NOFORN) Prior to the session the viewer was given a sealed envelope containing the attached photograph. He was also briefed on the attached RV Target Matry Chart. He was asked to focus during the session on the place in the photograph on 1 September 1981.
2. (S/NOFORN) After the session the remote viewer was shown the photograph in the sealed envelope and told that the photo was of a place in Germany.
3. (S/NOFORN) Further sessions are planned with this remote viewer. Feedback provided will serve to aid the viewer in target acquisition without providing "overlay" problems in later sessions.

~~SECRET~~

⊗ other events

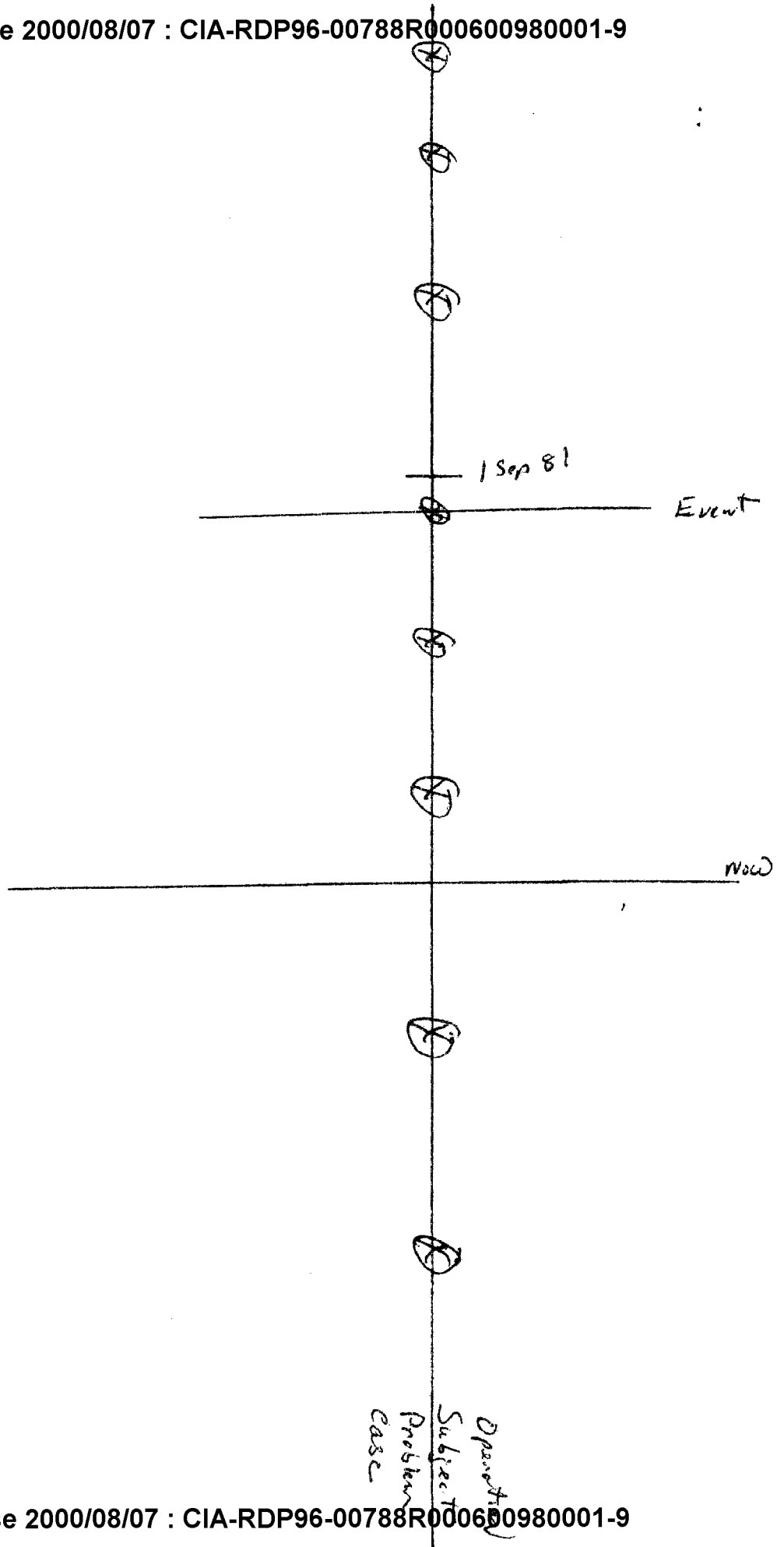

**SG1A**

**Approved For Release 2000/08/07 : CIA-RDP96-00788R000600980001-9**

**Approved For Release 2000/08/07 : CIA-RDP96-00788R000600980001-9**